

Please encourage the children to try and find the answers out themselves from looking at the boats and information around them. These notes are to help you do that.

Antelope I

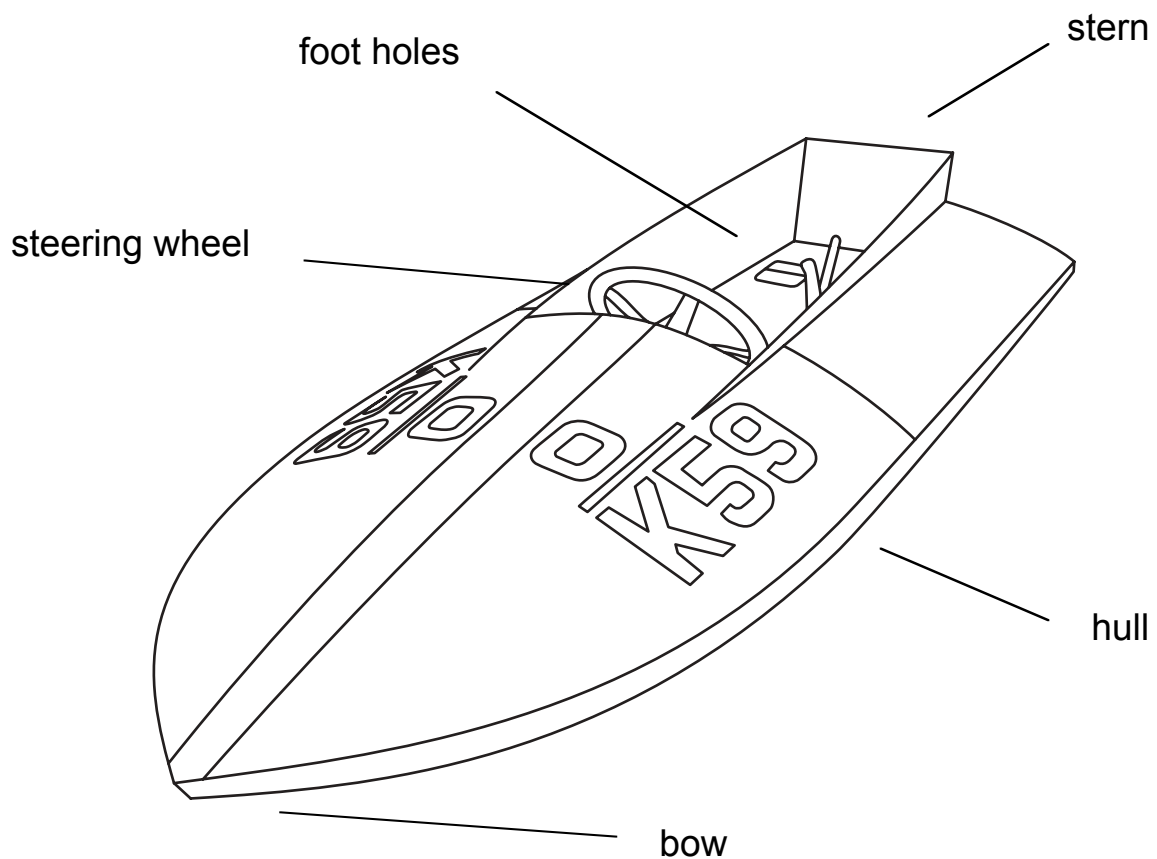

Antelope I was owned and raced by a man called Bert Savidge. In this type of racing boat the competitor knelt in the boat and put their feet in to the foot holes for stability. Bert Savidge won the Daily Mirror Trophy in August 1949. Antelope I is a kneeling hydroplane.

Apache

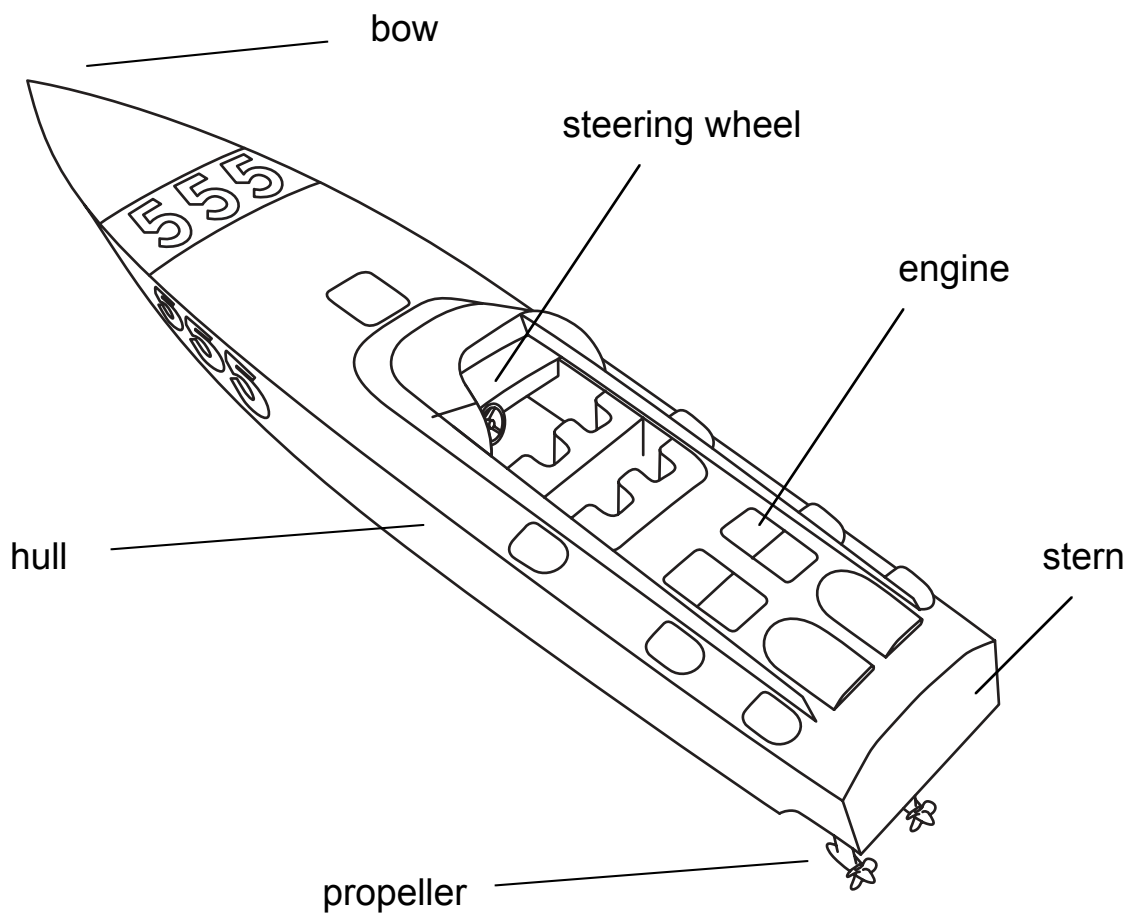

Apache was winner of the London Monte Carlo race in 1972 which is considered to be one of the toughest races. Apache is a monohull.

Donald Campbell

Donald Campbell had several boats but the one mentioned in the display is Bluebird K7. He was attempting to break the world water speed record.

He broke the record at Lake Coniston and the fastest speed he did was 276.30mph.

Hull shapes

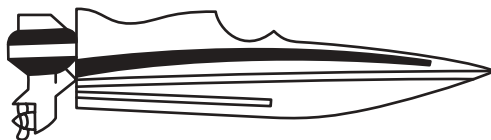

Monohull

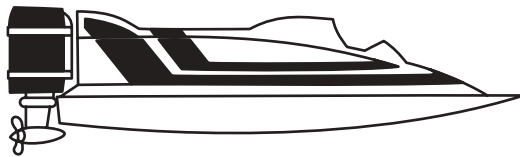
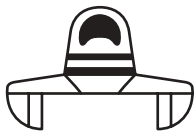

Catamaran



Hydroplane

Monohulls - a flaring V-shape that helps the front section of the hull to rise out of the water at high speed.

Catamarans - only the rear hulls (and their propeller and rudder) stay wet at race speeds, making them the fastest class of racer.

Hydroplanes - the twin hulls create "lift". At full speed they become airborne. Only the back hull stays in the water.